

Contract/Proposal No. 019988

POLYSMART

POLYgeneration with advanced Small and Medium scale thermally driven  
Air-conditioning and Refrigeration Technology

Integrated Project

Call: FP6-2004-TREN-3

Priority: SUSTDEV-1.1.4 - POLYGENERATION  
Demonstration Projects

## **D3-20 SP1a-System Assembled**

Due date of deliverable: month 23

Actual submission date: 2008-07-30

Start date of project: 2006-06-12

Duration: 48 months

Organisation name of lead contractor for this deliverable: Besel

Revision [final]

Project co-funded by the European Commission within the Sixth Framework Programme (2002-2006)		
Dissemination Level		
<b>PU</b>	Public	X
<b>PP</b>	Restricted to other programme participants (including the Commission Services)	
<b>RE</b>	Restricted to a group specified by the consortium (including the Commission	
<b>CO</b>	Confidential, only for members of the consortium (including the Commission Services)	

## Subproject SP1.a – system assembled/erected

### 1) Description of assembled system

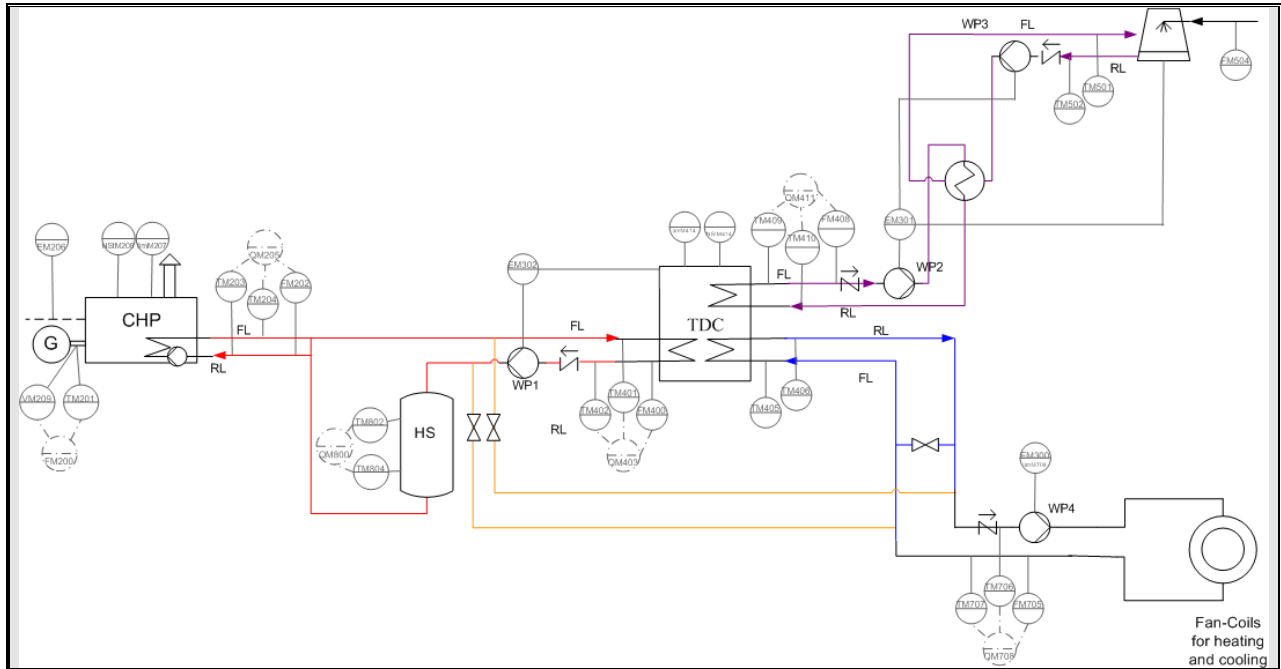

#### Kind of load, building description

The building selected for the project integration is the municipal Sport Centre “La Cantera”, located in Leganés (Madrid). The trigeneration installation will provide heating and cooling for the main entrance hall, where the existing central heating and cooling services of the building are not available.

The entrance hall is around 70 m<sup>2</sup> area and the reception desk is occupied by one or two persons. The sport centre is open from Monday to Saturday 9:00-22:30 and Sundays from 9:00 to 14:30h.

#### Heat and cold distribution system

A completely independent system, with no interference with the existing heating and cooling installation has been implemented for the trigeneration demonstration project. A two-pipe fan coils system has been designed for the cooling and heating of the entrance hall. Two fan coils have been installed in the hall, with 10 kW cooling capacity each one.

#### Heat rejection

Heat rejection is performed by means of a small open cooling tower installed over the building roof. The EWK 036/06 provides 30 kW rejection heat, with the following design conditions: 24°C dry bulb temperature, water flow of 3,3 m<sup>3</sup>/h, and 35 – 27°C water inlet and outlet temperatures.

#### mCHP

The micro-cogeneration module is a SENERTEC DACHS based on a combustion engine, with an electrical production of 5.5 kW and a thermal generation of 12.5 kW. The module is powered with natural gas.

#### TDC

The demonstration project includes a ClimateWell’s chemical heat pump, model CW10 capable of store energy and to deliver cooling and heating, up to 20 kW power.

## Storage

A 750 litres buffer tank has been installed for heating storage purposes. The tank is connected in series in the return line from the TDC to the CHP in order to allow higher temperatures of water feeding into the TCD, while maintaining the storage capacity.

## Data acquisition system

The data acquisition system used in the demonstration project has been developed by BESEL. The MicroSCADA control system is able to perform data acquisition from:

- 10 temperature sensors (Pt1000),
- 3 pulse flowmeters or other pulse sensors
- 0-20 mA / 4-20 mA sensors (2)
- ClimateWell 10 TDC.

The system includes data registration and automatic sending of historic files by e-mail to defined users; local and/or remote control over pumps, valves and any other element of the installation.

## Sensors

Code	Descriptive nomencl.	Description	Associated sensor name	Type of sensor	Manufacturer data
TM100	$T_{OA}$	Outside ambient air temperature (dry bulb)	$T_{OA}$	Testo Hygrotest	TESTO
HM101	$H_{OA}$	Outside ambient relative humidity	$H_{OA}$		
TM102	$T_{IA}$	Inside ambient air temperature in main hall	$T_{IA}$	Testo Hygrotest	TESTO
HM1031	$H_{IA}$	Inside ambient relative humidity in main hall	$H_{IA}$		
FM200	$F_{ChpGN}$	Fuel consumption flow rate	$F_{ChpGN}$	BK-G4 / IN-Z61	Kromschroeder
TM201	$T_{ChpGN}$	Temperature of gas fuel for flow correction	$T_{ChpGN}$	Pt1000	Resol FKP21
FM202	$F_{Chp}$	Heat recovery circuit flow rate	$F_{Chp}$	MC401 66-WS-7F7	Kamstrup
TM203	$T_{ChpRI}$	Flow temperature of heat recovery circuit, return line (inlet to CHP)	$T_{ChpRI}$		
TM204	$T_{ChpFI}$	Flow temperature of heat recovery circuit, feeding line (outlet of CHP)	$T_{ChpFI}$		
QM205	$Q_{Chp}$	Heat released to the heat recovery circuit			
EM206	$E_{PROD_{ChpNet}}$	Electric energy production of the CHP			Senertec
timM207	$tim_{Chp}$	Counter of running time of CHP			Senertec
NSiM208	$nStarts_{Chp}$	Number of starts of the CHP			Senertec
EM300	$E_{LOADSCircuits}$	Electricity consumption of loads circuits (pumps,...)	$E_{LOADSCircuits}$	Mk30-LCD	Circutor
EM301	$E_{RCCircuits}$	Electricity consumption of recooling circuits (pumps,...)	$E_{RCCircuits}$	Mk30-LCD	Circutor
EM302	$E_{OtherCircuits}$	Electricity consumption of other circuits (pumps,...)	$E_{OtherCircuits}$	Mk30-LCD	Circutor
FM400	$F_{TdcDc}$	Flow through driving circuit of the TDC	$F_{TdcDc}$	MC401 66-WS-7F7	Kamstrup
TM401	$T_{TdcDcFI}$	Flow temperature in feeding line (inlet to TDC) of the driving circuit of the TDC	$T_{TdcDcFI}$		
TM402	$T_{TdcDcRI}$	Flow temperature in return line (outlet from TDC) of the driving circuit of the TDC	$T_{TdcDcRI}$		
QM403	$Q_{TdcDc}$	Heat absorbed in the driving circuit of TDC			
TM405	$T_{TdcCcFI}$	Flow temperature in feeding line (inlet to TDC) of the cooling circuit of the TDC	$T_{TdcCcFI}$	Pt1000	Resol FKP21
TM406	$T_{TdcCcRI}$	Flow temperature in return line (outlet from TDC) of the cooling circuit of the TDC	$T_{TdcCcRI}$	Pt1000	Resol FKP21
FM408	$F_{TdcRc}$	Flow through recooling circuit of the TDC	$F_{TdcRc}$	MC401 66-WS-7F7	Kamstrup
TM409	$T_{TdcRcFI}$	Flow temperature in feeding line (outlet from TDC) of the recooling circuit of the TDC	$T_{TdcRcFI}$		
TM410	$T_{TdcRcRI}$	Flow temperature in return line (inlet to TDC) of the recooling circuit of the TDC	$T_{TdcRcRI}$		
QM411	$Q_{TdcRc}$	Heat exchanged in the Recooling Circuit of TDC			
EM412	$E_{tdc}$	Electricity consumption of the TDC	$E_{OtherCircuits}$		
timM413	$tim_{Tdc}$	Running time of TDC	$E_{OtherCircuits}$		
NSiM414	$nStarts_{Tdc}$	Number of starts of the TDC	$E_{OtherCircuits}$		
TM501	$T_{HrFI}$	Flow temperature in feeding line (inlet to HR) of the HR System	$T_{HrFI}$	Pt1000	Resol FKP21
TM502	$T_{HrRI}$	Flow temperature in return line (outlet from HR) of the HR System	$T_{HrRI}$	Pt1000	Resol FKP21
FM504	$F_{HrH2O}$	Water consumption in HR System	$F_{HrH2O}$	GSD-8R	B Meters

EM505	E <sub>hr</sub>	Electricity consumption of HR System	E <sub>RCCircuits</sub>		
FM700	F <sub>HDN</sub>	Flow to provide heat to end Use N (where HDN: SHeat for Space Heating, DHW, or VHeat for Vessel Heating,...)	F <sub>CDN</sub>		
TM701	T <sub>HDNFI</sub>	Flow temperature in feeding line of the service (inlet to Load).	T <sub>CDNFI</sub>		
TM702	T <sub>HDNRI</sub>	Flow temperature in return line of the service (outlet from Load).	T <sub>CDNRI</sub>		
QM703	Q <sub>HDN</sub>	Heat to end Use N (where HDN: SHeat for Space Heating, DHW, or VHeat for Vessel Heating,...)	Q <sub>HDN</sub>		
timM704	tim <sub>HDN</sub>	Running time of the heat distribution service.	E <sub>LOADSCircuits</sub>		
FM705	F <sub>CDN</sub>	Flow to provide cold to end Use N (where CDN: SCool for Space Cooling, or VCool for Vessel Cooling,...)	F <sub>CDN</sub>	MC401 66-WS-7F7	Kamstrup
TM706	T <sub>CDNFI</sub>	Flow temperature in feeding line of the service (inlet to Load).	T <sub>CDNFI</sub>		
TM707	T <sub>CDNRI</sub>	Flow temperature in return line of the service (outlet from Load).	T <sub>CDNRI</sub>		
QM708	Q <sub>CDN</sub>	Cold to end Use N (where CDN: SCool for Space Cooling, or VCool for Vessel Cooling,...)			
timM709	tim <sub>CDN</sub>	Running time of the heat distribution service.	E <sub>LOADSCircuits</sub>		
TM802	T <sub>heat storage FI</sub>	Temperature on the top of the heat storage	T <sub>HSFI</sub>	Pt1000	Resol FKP6
TM804	T <sub>heat storage RI</sub>	Temperature on the bottom of the heat storage	T <sub>HSRI</sub>	Pt1000	Resol FKP6
QM800	E <sub>heat Storage</sub>	Heat stored in the heat storage of the system			

## 2) Pictures of assembled system

