

DEVELOPING A SILICAGEL-WATER ADSORPTION CHILLER FOR MICRO-TRIGENERATION

*E.J. Bakker and R. de Boer,
Energy research Centre of the Netherlands (ECN), Petten, The Netherlands*

Abstract: Recently small-scale thermally driven chillers have gained a lot of interest because their potential to save primary energy, to reduce electricity peaks on the grids and to improve cost-benefit ratio of micro-CHP units when combined into tri-generation systems. ECN has developed a small-scale (output < 5 kW) silicagel-water adsorption chiller for comfort cooling for both stationary and mobile applications. At the moment a new prototype is being built (output 2.5 kW) for application in a micro-trigeneration system for residential application. The adsorption chiller will be driven by heat from a Stirling micro-CHP. The total system will be installed in an ECN research house, including the option of so-called solar cooling with solar collectors, and monitored extensively. A search for partners to commercialize the chiller for the built environment is ongoing.

Key Words: *adsorption, heat pump, silicagel, trigeneration, solar cooling*

1 INTRODUCTION

Within the EU there is a growing demand for comfort cooling in residential buildings. This increase is driven by rising outdoor temperatures and the standard set by already increased comfort levels in workplaces and transport (cars, trains etc). However, the current use of electrical compression cooling significantly increases primary energy usage, related CO₂ emissions and peak demands on the electricity grid. Thermally driven chillers (TDC) have gained a lot of interest because they use less primary energy (using 'waste' heat to drive the compression) and they don't create peak demands on the grid, while providing the same level of comfort. In addition, sorption chillers may use natural refrigerants that have zero ozone depletion potential and zero global warming impact. Combining TDC with the expected increase of micro-CHP in residential buildings leads to a concept for micro-trigeneration. Tri-generation concepts have the potential to save about 15% of energy for combined heat, cooling and power (CHCP) production, compared to conventional concepts of separate production (e.g. HE gas-fired boiler, compression chiller and electricity mix of the national grid). However, TDC's for residential applications (single family houses) are not yet widely available in the market.

Within the framework of the FP6 project PolySMART, ECN has continued development of a thermally driven adsorption chiller. The thermal compression in this heat pump is based on the adsorption of water vapour in silicagel. In 2004-2005 the first prototype was developed, aiming at 5 kW chilled water output. This prototype is currently being monitored as part of the HVAC of a building in Italy. Currently ECN is designing a second prototype of 2.5 kW thermal output and increased power density. This second prototype will be incorporated in a micro-trigeneration system (Stirling micro-CHP + TDC) and undergo an extensive monitoring program.

2 THE SILICAGEL-WATER CYCLE

The heat pump in development uses silicagel-water as the working pair. Silicagel is a non-toxic hygroscopic micro porous solid adsorbent material. It can adsorb up to 35 wt% of water onto its surface area when exposed to humidity. When the silicagel is heated the adsorbed water is released again. The heat pump cycle used is shown in Figure 1. It shows the isosteric chart of silicagel between 20 and 1 wt% of water. Starting from point 1 in the diagram, the 'wet silicagel' is heated with the available heat source. The temperature of the silicagel rises together with its equilibrium water vapour pressure to point 2, without changing its water content; the isosteric heating phase. From point 2 the silicagel loses water vapour to the condenser (point 5) and further heats up to point 3; the isobaric heating phase. The heat of condensation is cooled to the environment. The dried silicagel is then cooled to point 4 and the water vapour pressure decreases; isosteric cooling phase. From point 4 water vapour is absorbed again from the evaporator (6) at low pressure and the silicagel then reaches point 1 again; the isobaric cooling phase. The evaporation of water at low temperature (point 6) is used for cooling purposes.

The adsorption at low temperature and pressure and the desorption at higher temperature and pressure is referred to as thermal compression.

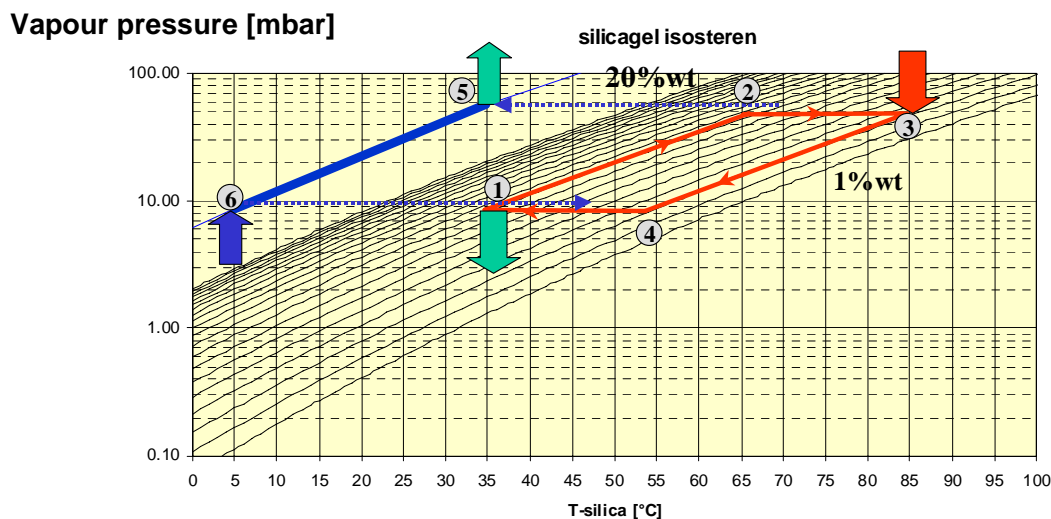

Figure 1: Isosteric chart of the silicagel-water system, together with the heat pump cycle

The cycle described above is a batch process. It is characterized by a regeneration phase (from 1 → 3) and a cold production phase (3→1). Depending on the type of silicagel used and the temperatures applied in the cycle the change in water uptake of the adsorbent ranges from just 2 to more than 15 wt%. A quasi-continuous cycle can be obtained by applying more than two silicagel beds working in counter-phase.

The cycle only uses thermal energy as input, and does not require any mechanical energy input, apart from pumps to circulate the heat transfer fluids for heating and cooling.

3 THE FIRST PROTOTYPE

Within the framework of the EU-Socool project a thermally driven chiller (TDC) was designed to produce 5 kW chilled water in the temperature range of 6-15°C for comfort cooling, driven by a heat source of 80-90°C from the cooling water circuit of a small gas-engine. The TDC was part of the small-scale trigeneration system installed in the ECO-canteen of CRF in Italy.

The basic lay-out and basic design of the system is shown below in Figure 2. The TDC contains two silicagel sorbent reactors that operate in counter phase. A more detailed description of the system can be found elsewhere [1].

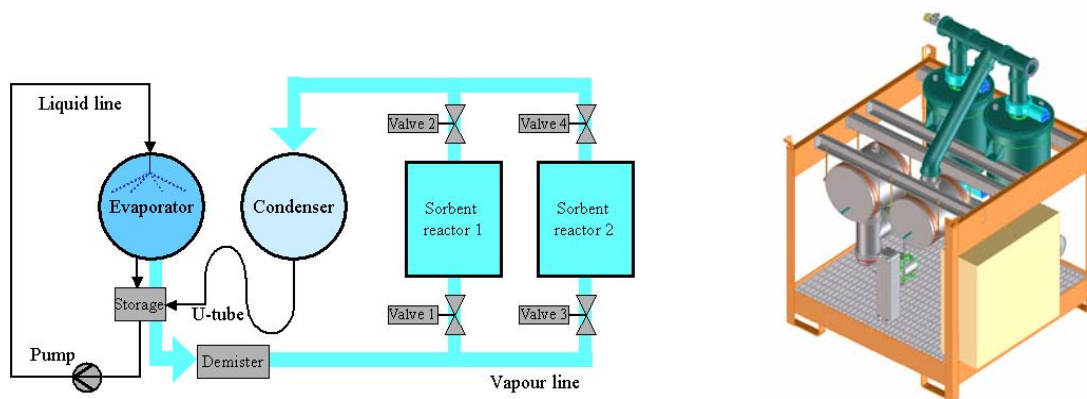

Figure 2: Basic lay-out (left) and basic design drawing (right) of the thermally driven chiller for the Socool project.

Before installing the TDC in the tri-generation system it was tested in the laboratory of ECN under various temperature conditions, to determine optimal operating conditions. The influence of the cycle time on the chilling power and the COP of the system are shown in Figure 3. The thermal insulation of the separate components led to low heat losses and made it possible to obtain a COP of 0.8 when applying extended cycle times. The chilling power however drops significant with long cycle times. A standard cycle time of 2 x 7 minutes was selected as a compromise between optimal chilling power and COP.

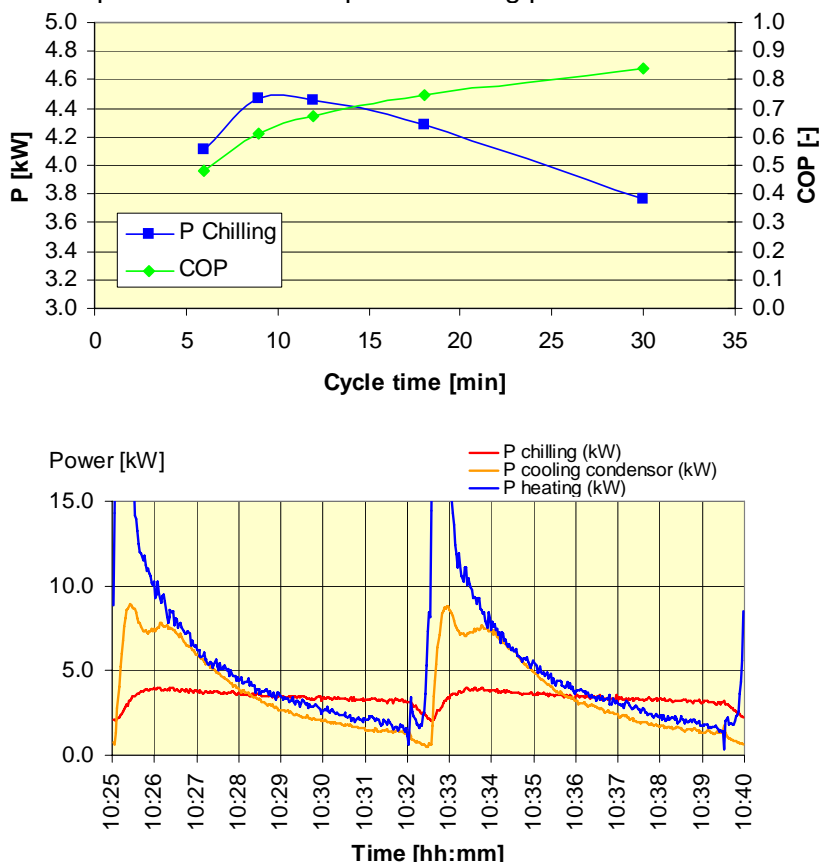

Figure 3: (Top) Chilling power and COP as a function of cycle time at inlet temperatures Heating 85°C, Tcooling 25°C, Tchilling 15°C. (Bottom) Thermal power levels over time during a typical working cycle of the TDC.

The thermal power uptake from the heat source strongly varies over the cycle time, see Figure 3 (bottom). Directly after switching over from heating silicagel bed 1 and 2, the cooler bed can take up a large amount of heat from the heat source due to the sudden larger temperature difference. This effect has to be carefully considered when integrating a TDC in a tri-generation system. In general, hot water storage tanks are used to smooth strong power and temperature fluctuations.

Figure 4 shows the tri-generation system installed in the basement of the CRF ECO-canteen in Italy.



Figure 4: Picture of adsorption cooling prototype system integrated in the tri-generation system of the ECO-canteen of CRF (Italy)

4 DESIGNING THE SECOND PROTOTYPE

From the work on this first TDC prototype the lessons learnt and improvements needed were carefully considered when starting the design work for the next prototype. Key issue was to drastically reduce the overall volume and weight of the TDC in order to allow installation in a single family house.

The main changes in comparison with the first prototype are:

- more compact design for the silicagel heat exchanger,
- use of plate-fin type heat exchanger for condenser,
- static evaporator (no refrigerant pump) using finned tube heat exchangers
- self actuated check valves in the refrigerant circuit between evaporator, reactor and condenser,
- closer packing of the thermal components,
- reduction of tube lengths and reduction in pressure drop in the liquid circuits,
- use of a liquid level control valve in the condensate return line.

These changes were made in order to allow the system size and volume to be within the dimensions of 60x60x100 cm (length x width x height). The basic design drawing of the TDC is shown in Figure 5. The use of more compact heat exchangers that contain the silicagel resulted from another prototype which was developed specifically for automotive air-conditioning application, within the framework of the EU sponsored TOPMACS project.

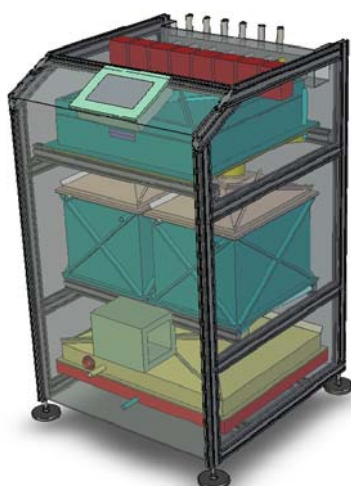

Figure 5: Basic design drawing for the TDC to be applied in the micro-trigeneration system.

The targeted nominal performance of the new prototype is to deliver 2.5 kW chilled water at 15/20°C for distribution in a floor cooling system in one of the research houses at the ECN premises. The hot water temperature is between 80-90°C and the cooling water temperature is 35°C under nominal conditions.

5 MICRO-TRIGENERATION SYSTEM

Within the FP6 project PolySMART [2] different micro-trigeneration systems are being developed. These systems consist of a micro-CHP (cogeneration of heat and power) of which the heat is used in summer to drive a thermally driven chiller. In the project twelve different combinations of technologies (absorption and adsorption chiller) and applications (residence, office, winery etc) will be realised and monitored extensively. ECN, the only Dutch partner in the project, will build a micro-trigeneration system for a single family house consisting of a Stirling micro-CHP and the thermally driven chiller described in this paper. The lay-out of the system is shown in the figure below.

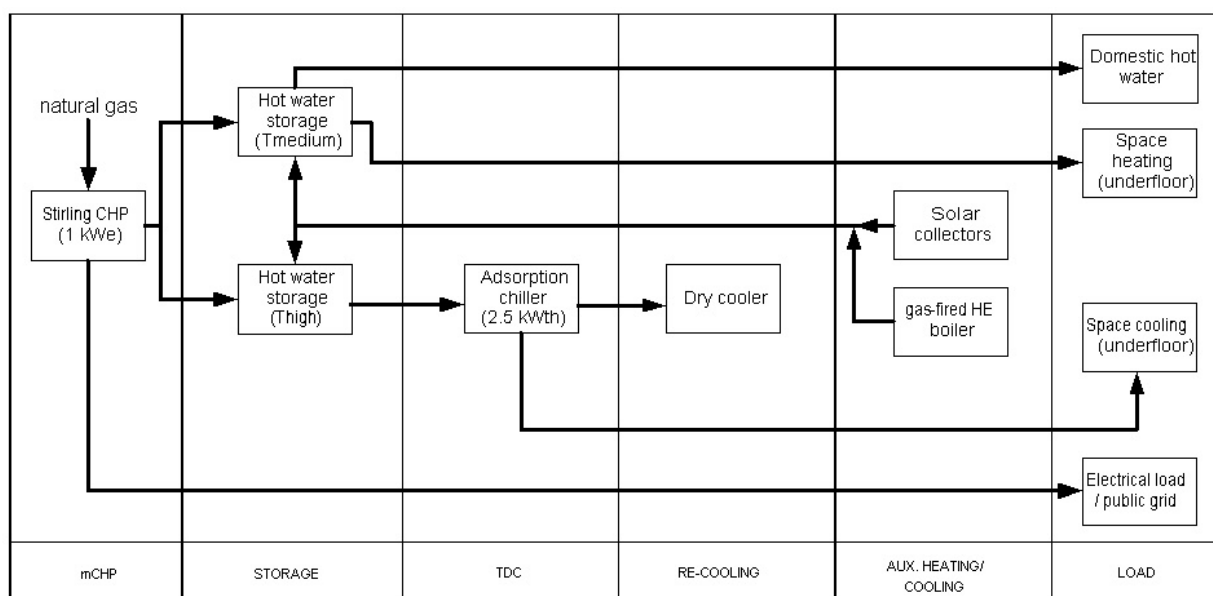

Figure 6 : Schematic of ECN PolySMART micro-trigeneration system

In winter the micro-CHP heats the house and a storage volume for domestic hot water. The co-produced power is used or exported to the grid. In summer the heat from the Stirling engine drives the chiller. Because of the batch behaviour of the chiller, it's expected a certain storage volume between micro-CHP and chiller will be required. For regeneration a standard dry cooler will be used. A gas-fired HE boiler will be installed as a back-up and the option will be incorporated to include solar collectors in order to test so-called solar cooling.

This system will be installed in one of the (energy efficient) research houses on the ECN premises in Petten. These houses represent the typical row house as commonly built and used in studies in The Netherlands. The houses are not inhabited but "average" occupant behaviour is simulated with weekly patterns for internal heat loads, use of domestic hot water, ventilation and temperature set points, and CO₂ and humidity production.



Figure 7: Picture of the test-houses at the ECN site where the micro-trigeneration system will be installed and tested

The micro-trigeneration concept is expected to save primary energy and CO₂ emissions compared to conventional heating (HE boiler) and cooling (compression chiller) options. The addition of cooling to micro-CHP is also expected to increase cost-benefit rate of micro-CHP because of increased operating hours (today micro-CHP in most cases suffers from the absence of a demand for the produced heat during summer).

6 CONCLUSION AND OUTLOOK

Recently small-scale thermally driven chillers have gained a lot of interest because their potential to save primary energy, to reduce electricity peaks on the grids and to improve cost-benefit ratio of micro-CHP units when combined into tri-generation systems. ECN has developed a small-scale (output < 5 kW) silicagel-water adsorption chiller for comfort cooling for both stationary and mobile applications. At the moment a new prototype is being built (output 2.5 kW) for application in a micro-trigeneration system for residential application. The adsorption chiller will be driven by heat from a Stirling micro-CHP. The total system will be installed in an ECN research house, including the option of so-called solar cooling with solar collectors, and monitored extensively. A search for partners to commercialize the chiller for the built environment is ongoing.

7 REFERENCES

- [1] De Boer, R, Smeding, S.F., Grisel, R.J.H, Performance of a silicagel+water adsorption cooling system for use in small scale tri-generation systems, Heat powered Cycles conference, September 2006.
- [2] www.polysmart.org