

1

Introduction

Ref.: TU Berlin (Anja Hanßke, Jan-Paul Kupser)

2

System Technology

Ref.: TU Berlin (Anja Hanßke, Jan-Paul Kupser)

3

Matched Systems

Ref.: TU Berlin (Anja Hanßke, Jan-Paul Kupser)

4

Economics

Ref.: Politecnico di Milano (Marcello Aprile, Alexandra Lozano)
TU Berlin (Anja Hanßke, Jan-Paul Kupser)



1 Introduction

Definitions

Distributed Energy Generation

- energy (heat, power, cold) generation close to the consumption point

CHP - Combined Heat and Power generation (cogeneration)

- generation of useful heat and power
- usage of heat for space and water heating
- usage of electricity within home or business
- sold back electricity into the electric power grid

MicroCHP - installation of less than 5 kW_e (for a house or small business)

MiniCHP - installation of more than 5 kW_e and less than 500 kW_e (for buildings or medium sized business)

CHCP - Combined Heat, Cooling and Power generation (Polygeneration)

- generation of electricity in addition to heat or cold
- usage of heat for industrial or domestic heating purposes
- usage of heat in thermally driven chillers (TDC) for cooling



1 Introduction

Definitions

Distributed Energy Generation

- energy (heat, power, cold) generation close to the consumption point

CHP - Combined Heat and Power generation (cogeneration)

- generation of useful heat and power
- usage of heat for space and water heating
- usage of electricity within home or business
- sold back electricity into the electric power grid

MicroCHP - installation of less than 5 kW_e (for a house or small business)

MiniCHP - installation of more than 5 kW_e and less than 500 kW_e (for buildings or medium sized business)

CHCP - Combined Heat, Cooling and Power generation (Polygeneration)

- generation of electricity in addition to heat or cold
- usage of heat for industrial or domestic heating purposes
- usage of heat in thermally driven chillers (TDC) for cooling



1 Introduction

Total fuel energy input (Q_{FUEL})

- thermal energy associated with the total fuel input
- quantity of fuel consumed multiplied by heating value of the fuel
- commonly accepted heating values:

1020 Btu per cubic foot of natural gas

10,157 Btu per pound of coal

138,000 Btu per gallon of diesel fuel

Btu (British Thermal Unit): 1BTU = 1,06kJ
(standard unit for measuring quantity of heat energy)

Thermal efficiency (total system efficiency) of a CHP system

- sum of the net useful power output (W_E) and net useful thermal outputs (ΣQ_{TH}) divided by the total fuel input (Q_{FUEL}):

$$\eta_o = \frac{W_E + \Sigma Q_{\text{TH}}}{Q_{\text{FUEL}}}$$

- CHP systems with a relatively high net useful thermal output typically correspond to total system efficiencies in the range of 60 to 85 percent

Effective Electric Efficiency

- allow for a direct comparison of CHP to conventional power generation system performance
- □ equals the efficiency of the conventional technology that otherwise would be used to produce the useful thermal energy output if the CHP system did not exist:

$$\epsilon_{\text{EE}} = \frac{W_E}{Q_{\text{FUEL}} - \Sigma (Q_{\text{TH}} / \alpha)}$$

<http://www.epa.gov/chp/basic/methods.html>



Decentralised Energy Generation



1 Introduction

Technical Principles of Cogeneration (1) [1]

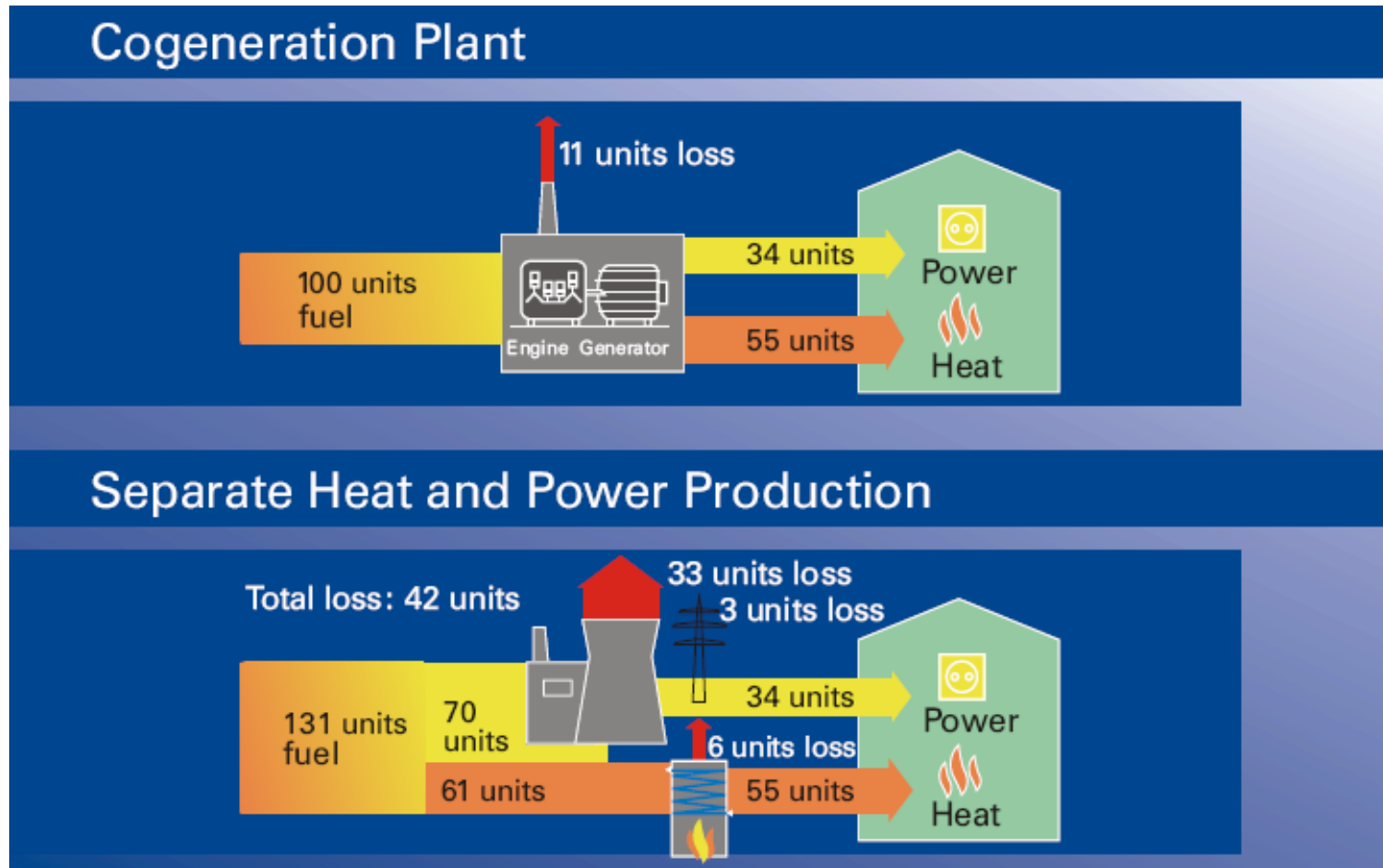

[1] <http://www.cogen-challenge.org> ; 19.11.2009



1 Introduction

Technical Principles of Cogeneration (2)

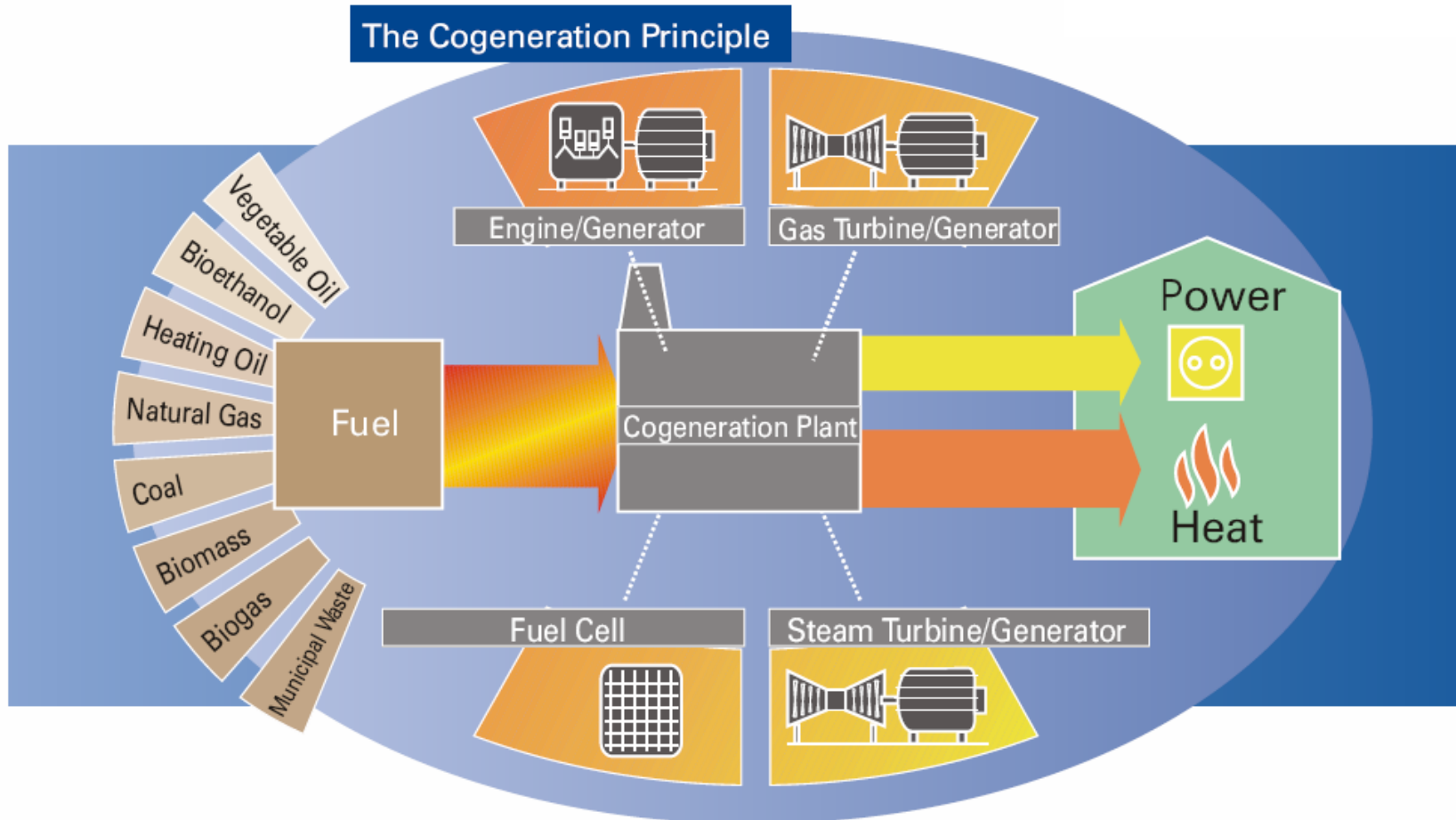

[1] <http://www.cogen-challenge.org> ; 19.11.2009



Decentralised Energy Generation



1 Introduction

Relevance of CHP- and CHCP-Systems

High fuel utilisation rate and usage of various heat sources

- decrease the consumption of primary energy by simultaneous generation of electricity and heat
- reduction of energy consumption for cooling by use of waste heat
- decrease the consumption of primary energy by using renewable energy sources (solar, biofuel, wood)
- reduction of harmful environmental emissions

High economic viability

- reduction of energy costs
- securing against energy price fluctuation
- large annual operation time by using waste heat for cooling

Installation close to the consumption point

- improvement of power supply reliability
- improvement of efficiency of electric utility services
- reduction of losses on the distribution grid
- alleviation of need for grid reinforcement
- alleviation of need for replacement of old central power plants
- solution for high-standard living comfort in the domestic sector



1 Introduction

Scheme of a CHCP-System

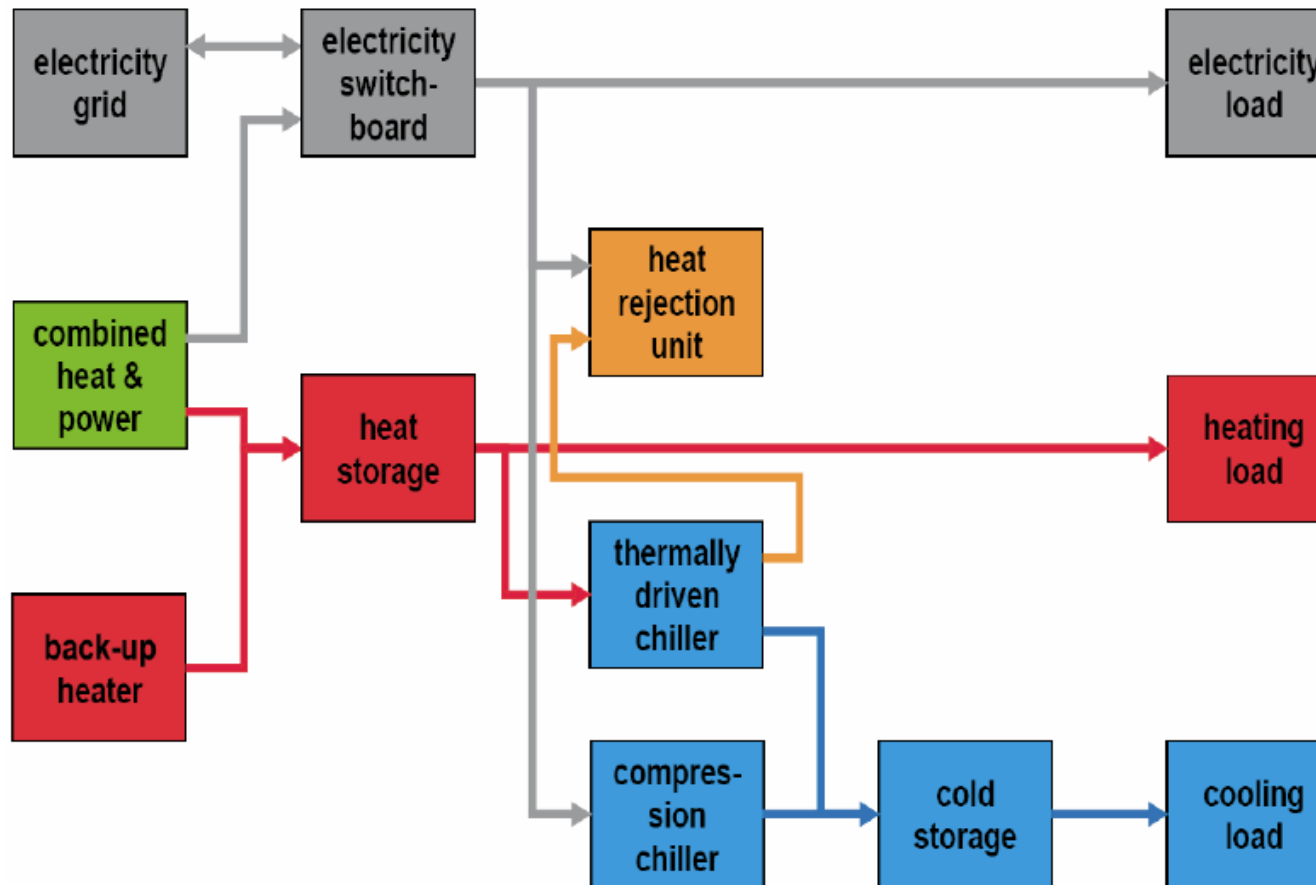

1 Introduction

Networking of CHCP-Systems

- centralised heat and power generation
- decentralised cooling
- TDC is connected to the district heating network

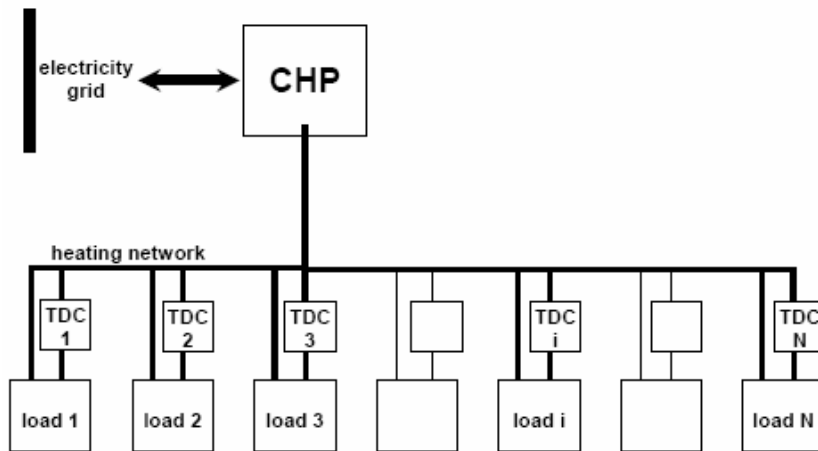

- decentralised heat and power generation
- decentralised cooling
- CHP unit is connected to the electricity grid

